

# TRANSPORTABLE JIB CRANE - JIB-P-10-10-8

APPROX WEIGHT: 667.70 lbs.  
DOES NOT INCLUDE WEIGHT OF POWER OR PACKAGING!!!

\*\*\* ANY ADDITIONS, DELETIONS, OR OMISSIONS MUST BE CORRECTED ON THIS DRAWING AS THIS DRAWING WILL BE CONSIDERED ALL INCLUSIVE \*\*\*

ALL GRAPHICS PROVIDED ARE FOR REFERENCE ONLY. IF CERTAIN DIMENSIONS ARE CRITICAL PLEASE VERIFY THOSE DIMENSIONS WITH YOUR SALESPERSON

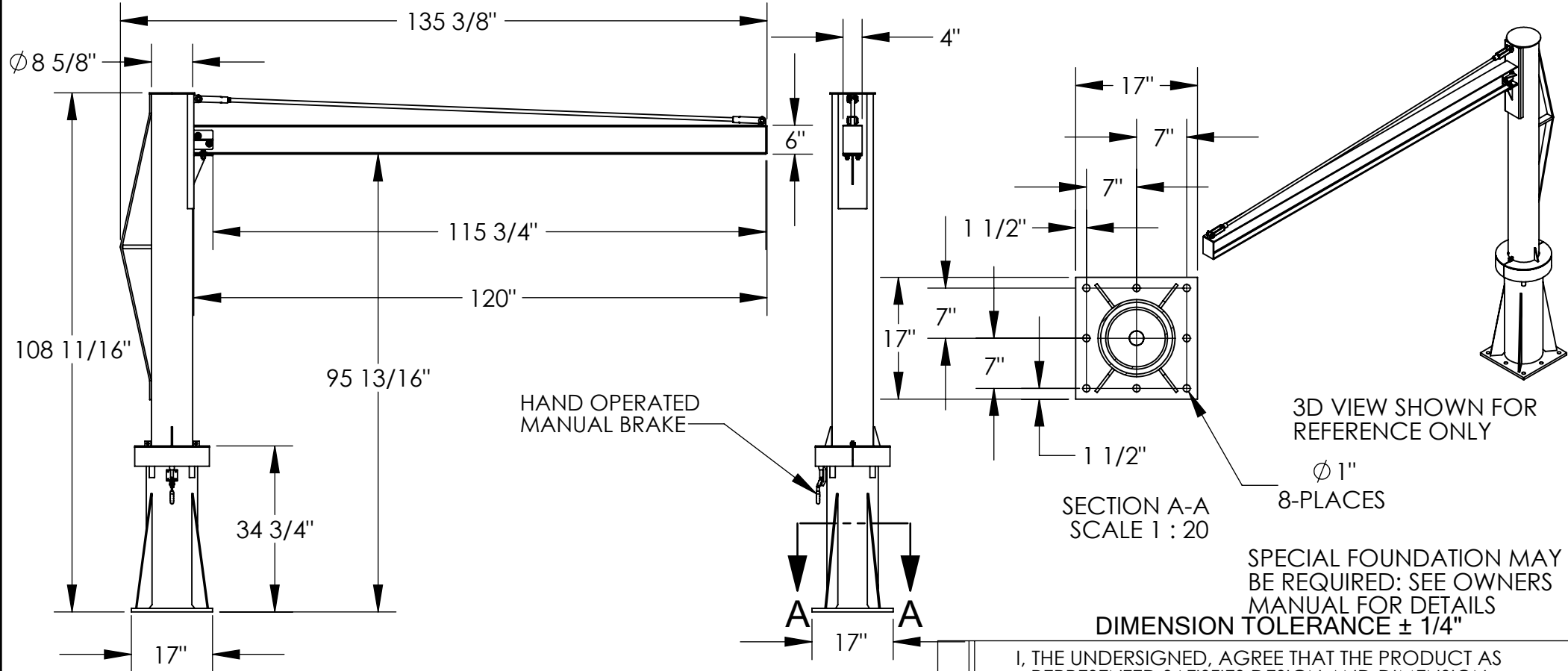

## STANDARD FEATURES

- MODEL NUMBER: JIB-P-10-10-8
- CAPACITY: 1,000 POUNDS
- OVERALL LENGTH: 135 3/8"
- OVERALL BOOM LENGTH: 120"
- USABLE BOOM LENGTH: 115 3/4"
- OVERALL HEIGHT: 108 11/16"
- USABLE HEIGHT: 95 13/16"
- I-BEAM SIZE: 6" HEIGHT X 4" FLANGE WIDTH
- UPRIGHT PIPE DIAMETER: 8 5/8"
- BASE SIZE: 17" X 17" X 34 3/4"
- WITH MOUNTING HOLES:  $\phi 1"$
- 360° CONTINUOUS ROTATION
- HAND OPERATED MANUAL BRAKE
- DURABLE LIQUID PAINT BLUE FINISH

## SPECIAL FEATURES

NONE

**A  
P  
P  
R  
O  
V  
A  
L**

I, THE UNDERSIGNED, AGREE THAT THE PRODUCT AS REPRESENTED SATISFIES DESIGN AND DIMENSION REQUIREMENTS. I ALSO ACKNOWLEDGE MY DUTY TO CONFIRM PRODUCT AND INSTALLATION COMPLIANCE WITH ALL APPLICABLE FEDERAL, STATE AND LOCAL REGULATIONS AND STANDARDS.

**UNITS REQUIRING APPROVAL DRAWINGS OR MODIFIED ARE NON-RETURNABLE**

[ ] As drawn [ ] As marked

Signed: \_\_\_\_\_ Date: \_\_\_\_\_

Printed Name: \_\_\_\_\_

LEAD TIME WILL START UPON RECEIPT OF SIGNED APPROVAL DRAWING

DISTRIBUTOR'S NAME:		P.O.#
VESTIL MANUFACTURING		X
DRAWN BY: ND		W.O.#
DATE: 8/14/09		X
REFERENCE: X	SCALE: 1:30	SALES: X
QUOTED LEAD TIME: X	QUOTE # X	FILE NAME:
		28-007-115